

B-Series

Direct-Fired Heating, Cooling and Ventilation Systems

- Improved indoor air quality – Helps dilute and expel airborne contaminants making exhaust systems operate more efficiently.
- Superior ventilation – System can be designed to automatically modulate outdoor air volume from 20% to 100% to meet ventilation requirements in cold weather and decrease heat buildup in warm weather.
- Consistent temperatures and less stratification – Optional cooling effectively reduces indoor air temperatures to help keep people and processes productive.
- Cost savings – Heating systems deliver 100% of the heat generated into the building resulting in energy savings.
- Flexibility and convenience – Heating systems require little to no ductwork and can be installed indoors or outdoors.
- Evaporative and mechanical cooling packages available.

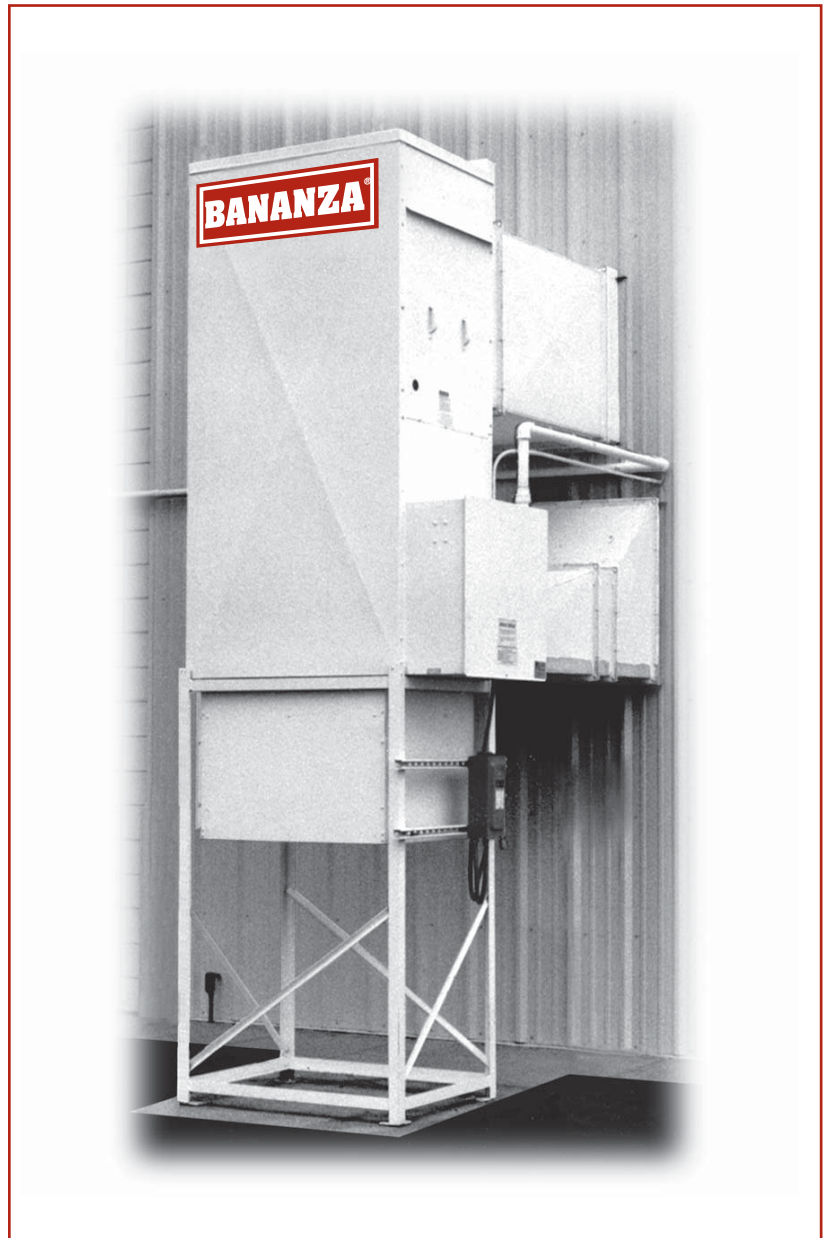

1.800.255.3416



CANADA: 100% OUTSIDE AIR ONLY

BANANZA[®] B-Series

BANANZA[®] B-Series air handlers improve indoor air quality and provide air comfort.

BANANZA[®] B-Series air handlers can be designed to efficiently establish and maintain a slightly pressurized condition in your facility as outdoor air is gently tempered and, as required, mixed with existing indoor air.

NOTE: All models are available in upright or horizontal as well as indoor or outdoor configurations.

Model	B-350	B-650	B-1000	B-2000	B-3000	B-4000	B-5000
CFM	1,000 - 4,000	4,000 - 10,000	7,000 - 14,000	12,000 - 25,000	25,000 - 40,000	35,000 - 47,500	45,000 - 60,000
Output [MBH]*	110 - 400	440 - 756	760 - 1500	1300 - 2700	2700 - 4100	3780 - 5130	4860 - 6480

* 1 MBH = 1,000 Btu/h

Model Configurations

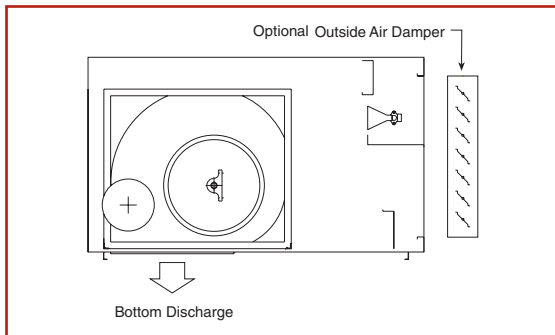

Make-Up Air (MUA) Models

Design: 100% replacement air with a fixed discharge air volume.

Function: Supplies direct replacement air for building mechanical exhaust.

Application: Used as make-up air for industrial processes which incorporate mechanical exhaust.

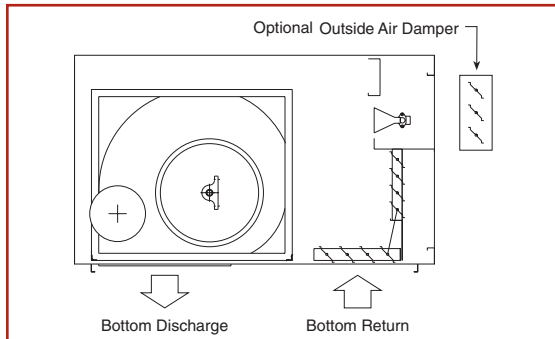

Air Management (AM) Models

(Not available on Model B-350)

Design: Variable outdoor air from 20% to 100% and a modulating burner with a 30:1 turn-down ratio. Discharge air volume is fixed.

Function: Automatically responds to building pressure and temperature needs.

Application: Used in industrial and commercial buildings that have air quality and specific air management requirements.

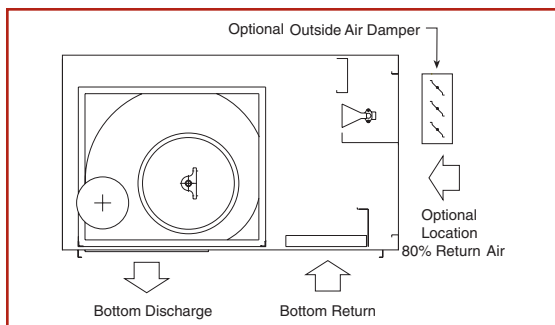

Fixed Recirculation (FR) Models

(Not available on Model B-350)

Design: Fixed 80% air turnover rate and 20% outdoor air replacement rate. Discharge air volume is fixed.

Function: Provides efficient, low-cost heating where minimum ventilation rates are required.

Application: Used in warehouses, distribution centers, retail outlets, etc.

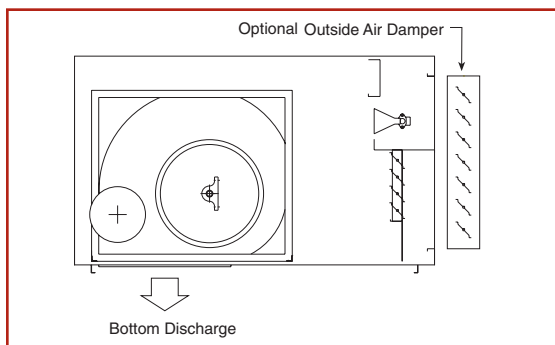

Spray-Cure[™] (SC) Models

(Not available on Model B-350)

Design: Discharge air volume is variable.

Function: Supplies direct replacement air for spray booth mechanical exhaust.

Application: Used as make-up air for paint booths.

BANANZA® B-Series Features

Reliable, Efficient System Operation Provided by:

- 30:1 fully modulating burner that maintains 100% combustion efficiency.
- Double-width, double-inlet, forward-curved centrifugal fan built for long life.
- Energy-saving ignition system.
- System that puts 100% of the available heat in the airstream, not out a flue.
- Unit that uses up to 50% less energy.
- Remote Control Panel for easy operation and remote temperature adjustment.
- Electronic fuel modulation providing immediate response.
- UV scanner for excellent reliability and durability on Models B-650 — B-5000.
- Temperature dial for quick, easy adjustment.
- Operation of fan only in warm weather to enjoy free ventilation cooling.
- Compliance to ETL per ANSI Z83.18 or Z83.4 standards.
- Industry-leading 80-point checklist to help facilitate trouble-free startup.

Ease of Maintenance Provided by:

- Large access panel for easy maintenance of blower, motor, drives and burner.
- Blower installed downstream of burner for convenient access.

Other B-Series Options:

- 10" or 20" Roof Curb simplifies rooftop mounting.
- Inlet Hood protects against water entrainment.
- Filter Section with polylink or aluminum filters for longer equipment life of internal components.
- Motorized Inlet Damper for exfiltration control.
- FM/IRI approved gas trains.
- Upright heater stand or legs of varying heights.

B-Series Conventional Controls' Options:

- Low-temperature automatic shutdown.
- Space temperature control for added comfort.
- 7-day time clock.
- Remote Control Panel with burner and blower switches for easy operation.
- Mild weather stat.

Long Lasting Construction Provided by:

- Heavy-duty, corrosion-resistant, galvanized steel construction.
- Sturdy, integral frame that is screwed and bolted together for durability and longer service life.
- Unpainted galvanized steel or white finishes available.
- Heavy-duty, factory-installed motor and drive package designed for long-lasting, performance.
- Heavy-duty, pre-lubricated bearings provide up to 30,000 hours of ABMA L-10 performance.

BANANZA® B-Series Optional Cooling Packages

Evaporative Cooling

BANANZA® B-Series evaporative cooling system is an economical solution. It requires no air-cooled condenser, no chiller or cooling tower, no chilled water pumps or distribution piping/insulation, no major motor control center or electrical gear. Operating costs are a fraction of similar-capacity mechanical refrigeration systems.

Evaporative cooling works when warm air passes over specially treated wetted media. The heat passes from the air to the wetted media, causing the water to evaporate and inside air to cool.

Mechanical Cooling

For situations requiring temperature and humidity levels lower than the performance parameters available with outdoor air alone or with evaporative cooling, BANANZA® B-Series offer a broad range of cooling options.

Cooling options can be added by simply installing one of our coil sections equipped with the appropriate cooling coils and a condensing unit or chiller. The versatility afforded by the coil section enables you to utilize DX refrigerant, chilled water or other types of cooling coils in your system.

Typical Installations

Mezzanine-Supported

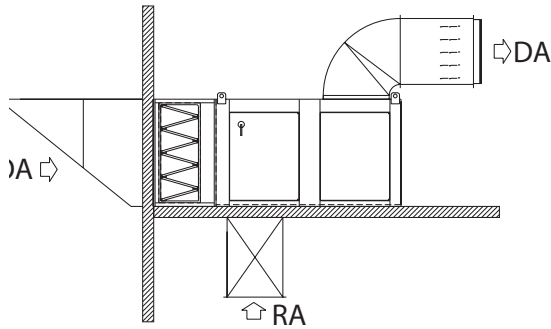

Roof-Mounted

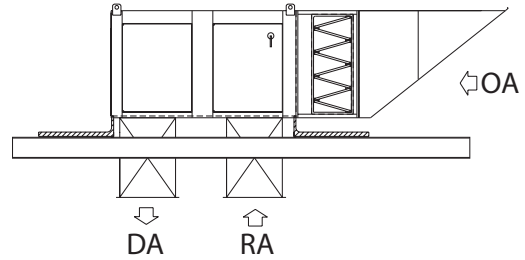

Suspended (Wall or Roof Inlet)

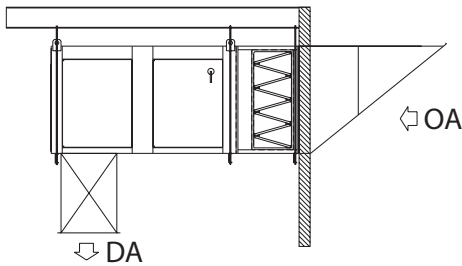

Horizontal on Legs (Indoor or Outdoor)

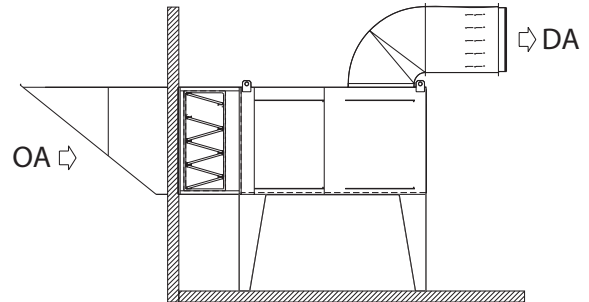

Upright Outdoor

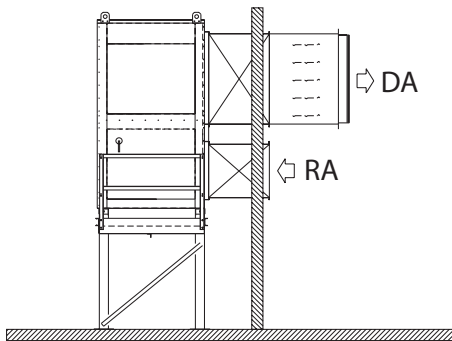

Upright Indoor

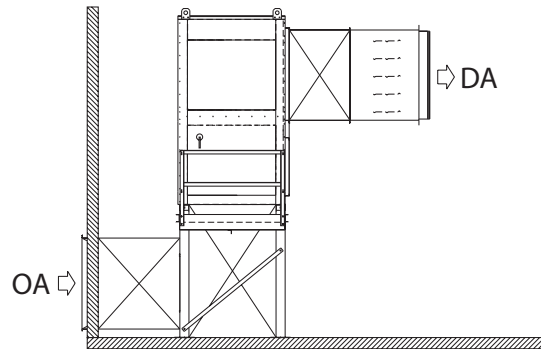

LEGEND

OA = Outside Air

DA = Discharge Air

RA = Return Air

Installation Code and Annual Inspections:

All installations and service of BANANZA® products must be performed by a contractor qualified in the installation and service of products sold and supplied by Bananza and conform to all requirements set forth in the Bananza manuals and all applicable governmental authorities pertaining to the installation, service and operation of the equipment. To help facilitate optimum performance and safety, Bananza recommends that a qualified contractor annually inspect your BANANZA® products and perform service where necessary, using only replacement parts sold and supplied by Bananza.

Further Information: Applications, engineering and detailed guidance on systems design, installation and product performance is available through BANANZA® representatives. Please contact us for any further information you may require, including the Installation, Commissioning, Operation and Service Manual.

This product is not for residential use.

This document is intended to assist licensed professionals in the exercise of their professional judgement.

Bananza

1100 Seven Mile Road NW
Comstock Park, MI 49321
Telephone: 616.726.8800
Toll Free: 800.255.3416
Fax: 616.726.8807
www.bananza.com

© 2007 Roberts-Gordon, LLC

All rights reserved. No part of this work covered by the copyrights herein may be reproduced or copied in any form or by any means – graphic, electronic, or mechanical, including photocopying, recording, taping, or information storage and retrieval systems – without written permission of Roberts-Gordon, LLC.